



## 户外高压启动电阻器 Outdoor high-voltage start-up resistors

### 产品概述

#### Product Introduction

svg启动电阻器是一种用于高压直流输电系统的启动电阻，其作为无功补偿设备以补充电网中所消耗的无功功率，从而降低电网中线路或变压器中的电能损耗，有助于提高电网质量。

svg start resistor is a kind of start resistor for HVDC transmission system, which is used as reactive power compensation device to supplement the reactive power consumed in the grid, thereby reducing the power loss in the grid line or transformer, and helping to improve the quality of the grid.

由于高压直流输电系统是设置在户外的，svg启动电阻器也在户外使用。现有技术中，陶瓷管具有绝缘性和密封性，因而，陶瓷管常被用作svg启动电阻器的电阻管，然后在电阻管内设置电阻丝。

Since HVDC transmission systems are set up outdoors, svg start resistors are also used outdoors. In the prior technology, the ceramic tube has the property of insulation and sealing, so the ceramic tube is often used as the resistance tube of the svg starting resistor, and then the resistance wire is set in the resistance tube

### 功能特点

#### Functional Characteristics

svg启动电阻器，电阻丝设置在瓷管内，瓷管内壁和电阻丝之间填充有绝缘填充物，瓷管两端外壁面再浇注有环氧树脂；环氧树脂是一种导热系数高的高分子聚合物，将其浇注在瓷管外壁能提高瓷管的散热性能和抗冲击柔性，从而改善了电阻器的电气稳定性和提高了电阻器的防破裂性能；另外，环氧树脂进一步地密封电阻器整体，减少电流谐波对输电系统的影响，利于提高输电系统的稳定性。

The svg starts the resistor, the resistance wire is arranged in the porcelain tube, the inner wall of the porcelain tube and the resistance wire are filled with insulating filler, and the outer wall of the porcelain tube is poured with epoxy resin; Epoxy resin is a kind of polymer with high thermal conductivity. Pouring it on the outer wall of porcelain tube can improve the heat dissipation performance and impact resistance flexibility of resistor. In addition, the epoxy resin further seals the whole resistor, reduces the influence of current harmonics on the transmission system, and is conducive to improving the stability of the transmission system.



### TYPICAL CIRCUIT DIAGRAM

#### 典型电路图

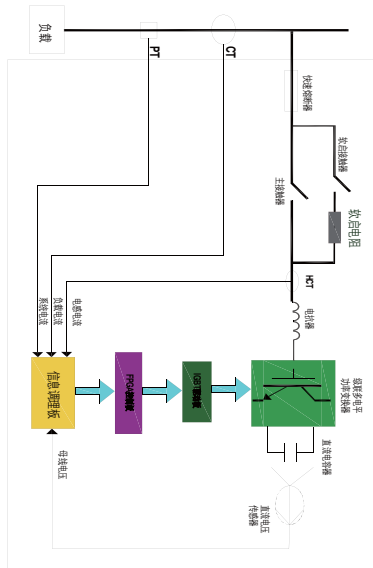

### 降额曲线

#### Rundown Curve

环境温度 Ambient temperature	0-20℃	>20℃
功率损耗 Power loss	100%	See figure

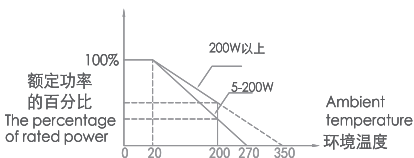

### 表面温升

#### Surface Temperature Rise

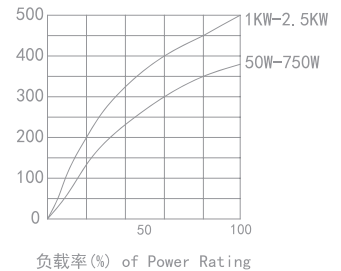

### 产品尺寸图

#### Product Size

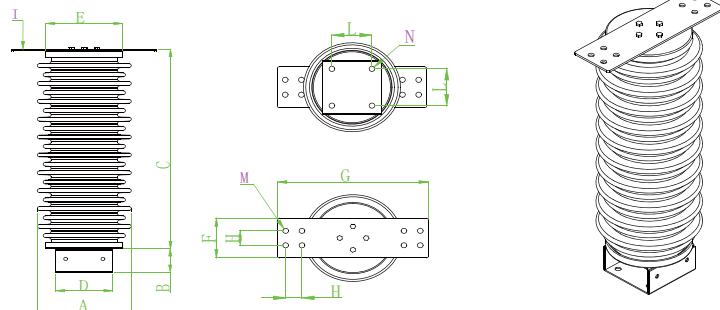

规格 TYPE	系统电压 voltage(kV)	冲击能量 Impact energy(KJ)	阻值 Resistance	尺寸Dimension										
				A±5%	B±1%	C±5%	D±1%	E±2%	F±1%	G±1%	H±1%	L±1%	M±1%	N±1%
RXHG	35	60	1200R±5%	198	74	651	116	152	80	330	40	70	14	14
RXHG	35	100	1200R±5%	240	74	625	146	197	110	370	40	99	14	14
RXHG	35	200	1200R±5%	300	74	795	168	227	110	440	40	99	14	14
RXHG	66	200	1200R±5%	300	74	795	168	227	110	440	40	99	14	14

### 使用环境

#### Operating environment

海拔高度不超过2000米。  
The altitude does not exceed 2000 meters.

运行环境温度-25℃~+45℃，相对湿度不超过90%。  
The operating environment temperature is -25℃ to +45℃, and the relative humidity does not exceed 90%.

周围无有害气体，无易燃易爆物品。  
There are no harmful gases around, no inflammable and explosive products

周围环境应有良好的通风条件，如装在柜内，应加装通风设备。  
The surrounding environment should have good ventilation conditions. If installed in a cabinet, ventilation equipment should be installed.